

BRAVAT TRIO COMMERCIAL AUTOMATIC MOTION CHROME SENSOR FAUCETS IN CHROME SPECS

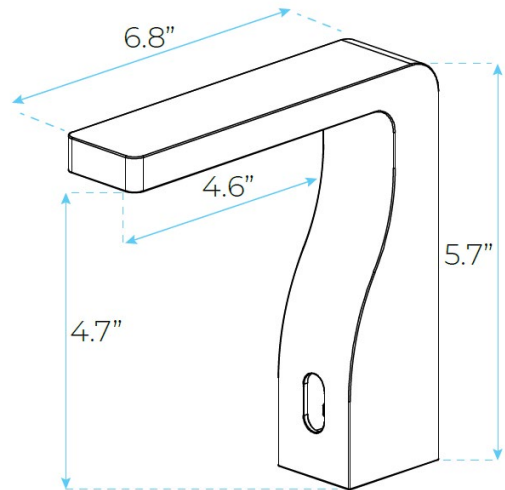

SPECS:

Power: DC:6V(4AA alkaline battery)
 AC:220V-240V; 50/60HZ
 Detection Zone: 16-32 cm or adjustable
 Motor valve lifespan: up to 500000 flushes
 Battery lifespan: 100000 cycles
 Static Power Consumption: 0.36mw
 Working Power consumption: 0.5mw
 Inductive Opening Time: < 1 second
 Inductive Closing Time: < 2 second
 Flow rate at 3 bar flow pressure for basin: ≥ 12 L/min
 Flow pressure: min. 0.5 bar
 recommended 1 –5 bar
 Operating pressure: max. 10 bar
 Test pressure: 16 bar

